



ERCOT's Experiences in Using Pseudo Measurements in State Estimation

Murali Boddeti, Diran Obadina, Freddy
Garcia, N. D. R. Sarma, Yang Wu*, Venkata
Kanduri

Electric Reliability Council of Texas, Inc.

*Alstom Grid

**IEEE PES Panel session on
'State Estimation Pseudo Measurements'
July 2011, Detroit**

- ❑ **Single Interconnection, with no synchronous ties to any other region in North America**
- ❑ **Responsible for all transmission equipment operating at 60 kV and above (69, 138, 345 kV)**
- ❑ **Five DC Ties to external regions**
 - 1 in North Texas, 1 in East Texas, 3 to Mexico
- ❑ **Utilizes Alstom's EMS for its Real-Time Network Security Analysis applications**
- ❑ **Facilitates competitive markets to help achieve reliability**
- ❑ **Operates as Nodal Market as of 1st Dec, 2010**

About ERCOT

- ❑ 85% of Texas load
- ❑ 550 generating units, ~6000 buses; ~7000 branches
- ❑ Peak demand: 65778 MW (08/23/2010)
- ❑ Wind capacity: 9500 MW
- ❑ Wind generation record: 7355 MW (06-19-2011), ~15% of load at that time

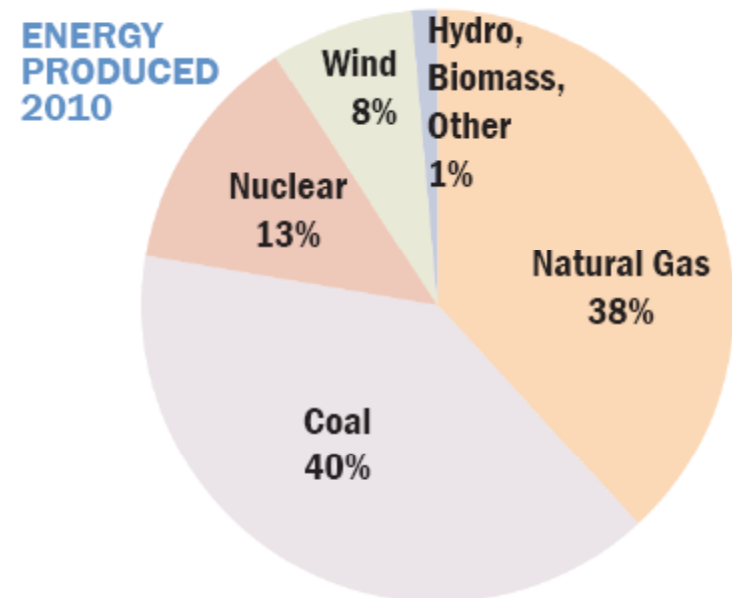
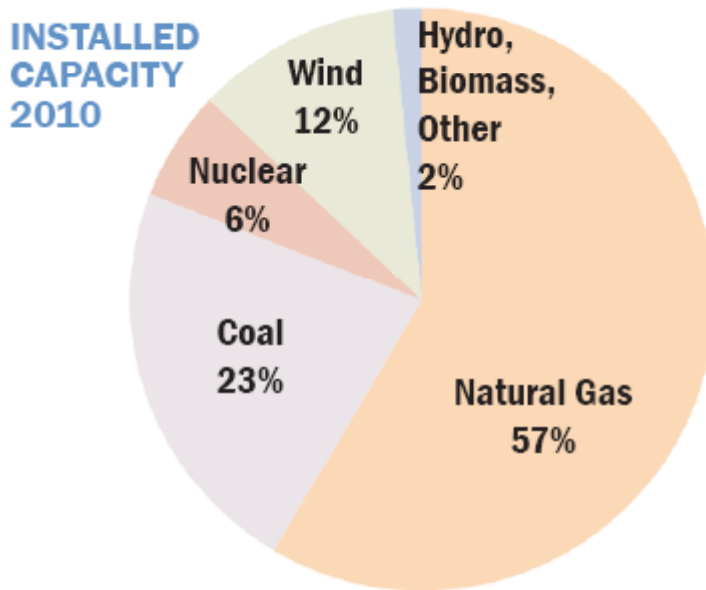

ERCOT

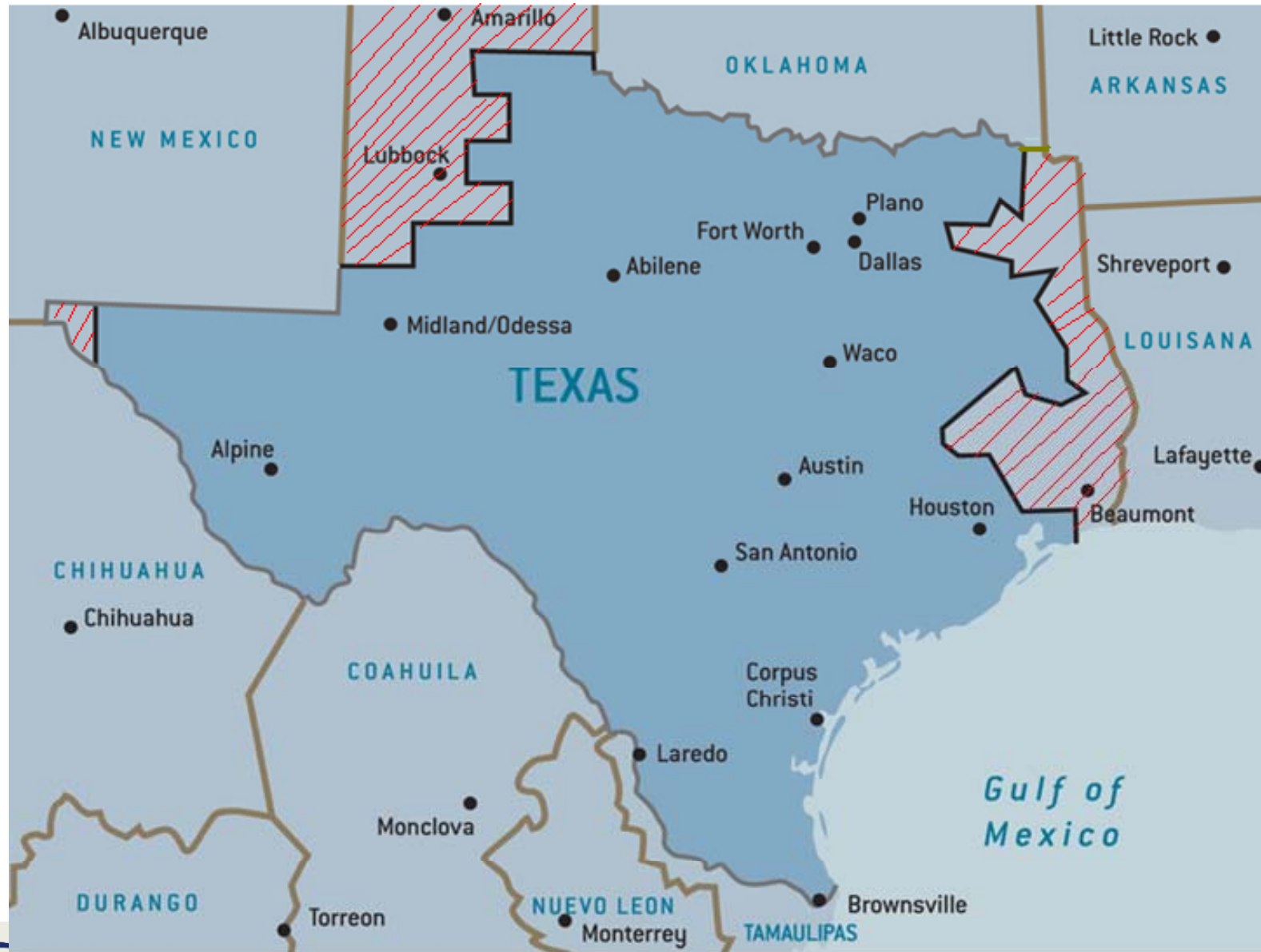

- ❑ **Filters redundant real time measurements – eliminates incorrect measurements**
- ❑ **Produces a Real Time Network model**
 - Allows determination of power flows in areas not directly metered
 - Used for real time monitoring
 - Used for real time Market and congestion management
 - Used to uncover potential operational problems related to n-1 security, voltage and transient stability
- ❑ **Results used for adapting the load parameters**
 - Used for Day-Ahead Market and other forward markets
 - Off-line power flows and stability studies

- ❑ **Conventional State Estimator , i.e., RT modeling decomposed into (1) Processing statuses of switches (2) Processing of analog data, given network topology and parameters**
- ❑ **Uses MW/MVAR, KV, tap.**
- ❑ **Executes periodically (5 mins); on demand; or grid event**
- ❑ **RT measurements collected via ICCP links with TSPs every 10 secs**
- ❑ **Network observability of over 99%**
- ❑ **Measurement redundancy of about 2.0**

- ❑ **Unobservable buses result from**
 - Temporary loss of ICCP link
 - Temporary loss of measurement point (from the RTU)
 - Unavailable/inadequate measurements
- ❑ **Unavailable/inadequate measurements typically at lower KV level (69KV); typically affecting radial lines and tap loads**
- ❑ **SE extended to unobservable buses through the addition of Pseudo measurements**
- ❑ **Challenge is to avoid corrupting the states estimated from telemetry**

Handling Temporary Loss of Telemetered Data

- ❑ Continue to use old telemetered values for a configurable number of SE executions cycles(several minutes)**
- ❑ Progressively reduced measurement confidence values (increased measurement variance)**
- ❑ Stale measurements subsequently dropped and replaced with pseudo measurements based on load predictions and generation schedules**

- ❑ **Calculated based on telemetered values**
 - Predefined Calculated point in SCADA (RTMONI)
 - Topology-based Calculated Point (CALCM)

- ❑ **Load Schedules**

- ❑ **Operator Overrides**

- Short-term SCADA calculation tool**
- Used until the telemetry is available at calculated point**
- Can be defined online without DB load**
- Ease of use made a tool for pseudo measurement modeling by the shift engineer**

RTMONI Calculation

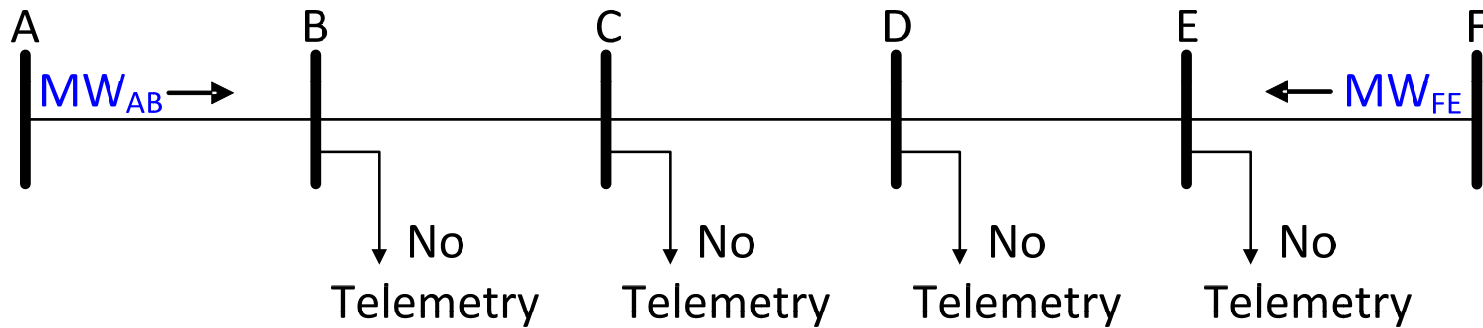

Fig1. Example without RTMONI Calculations

RTMONI Calculation

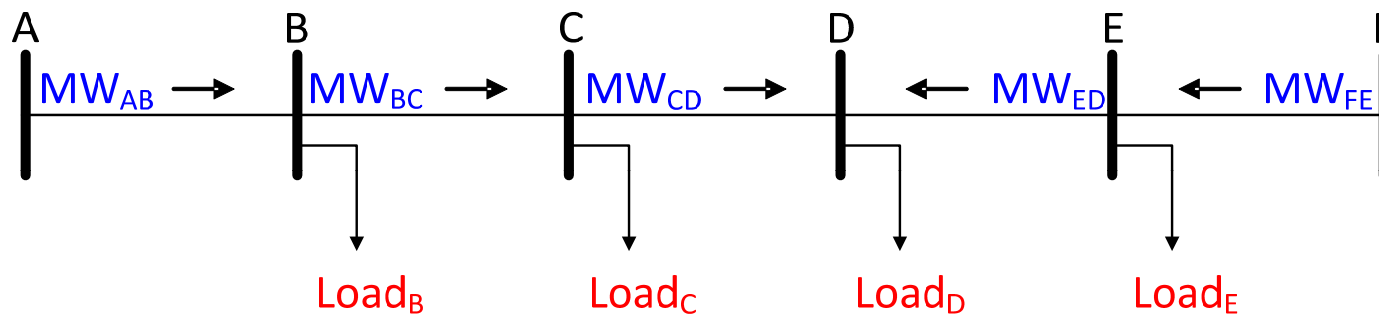

Fig2. Example with RTMONI Calculations

- Addition of calculated measurements using network topology information**
- Accurate than RTMONI**

CALCM Function

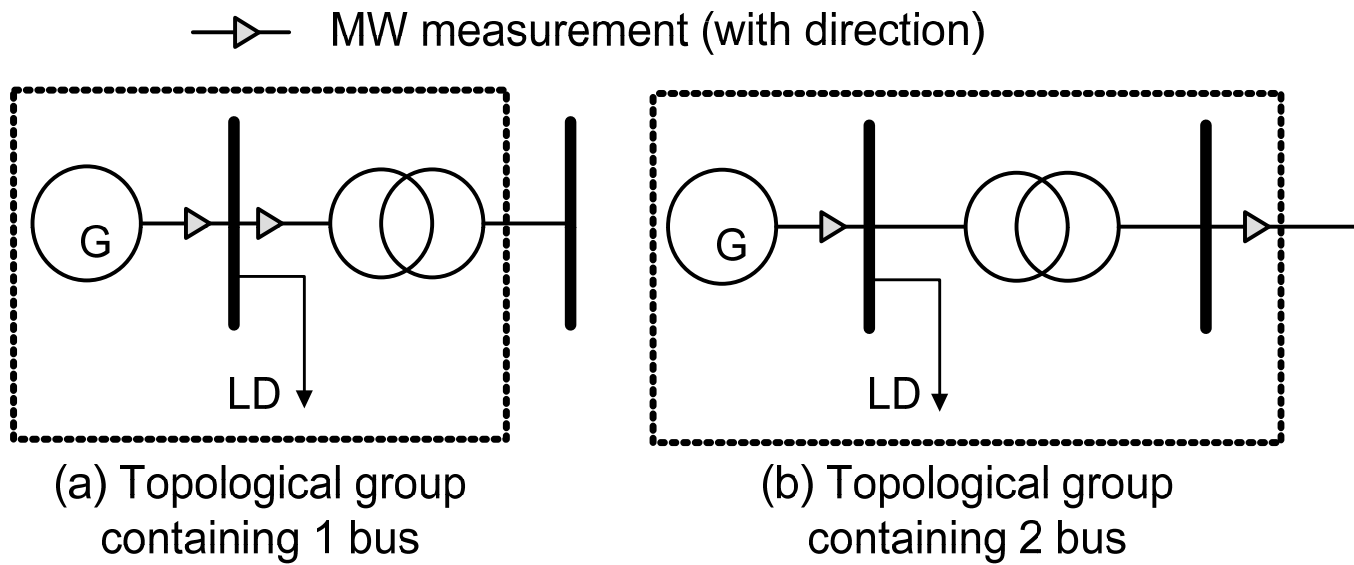

Fig 4: CALCM Calculations

- Classified into various weather zones in Texas**
- Conforming and non-conforming classification**
- Used as pseudo measurement when telemetry is unavailable**
- Adapted in real-time with SE results**
- Adapted parameters used in study applications and forward markets**

Load Schedules

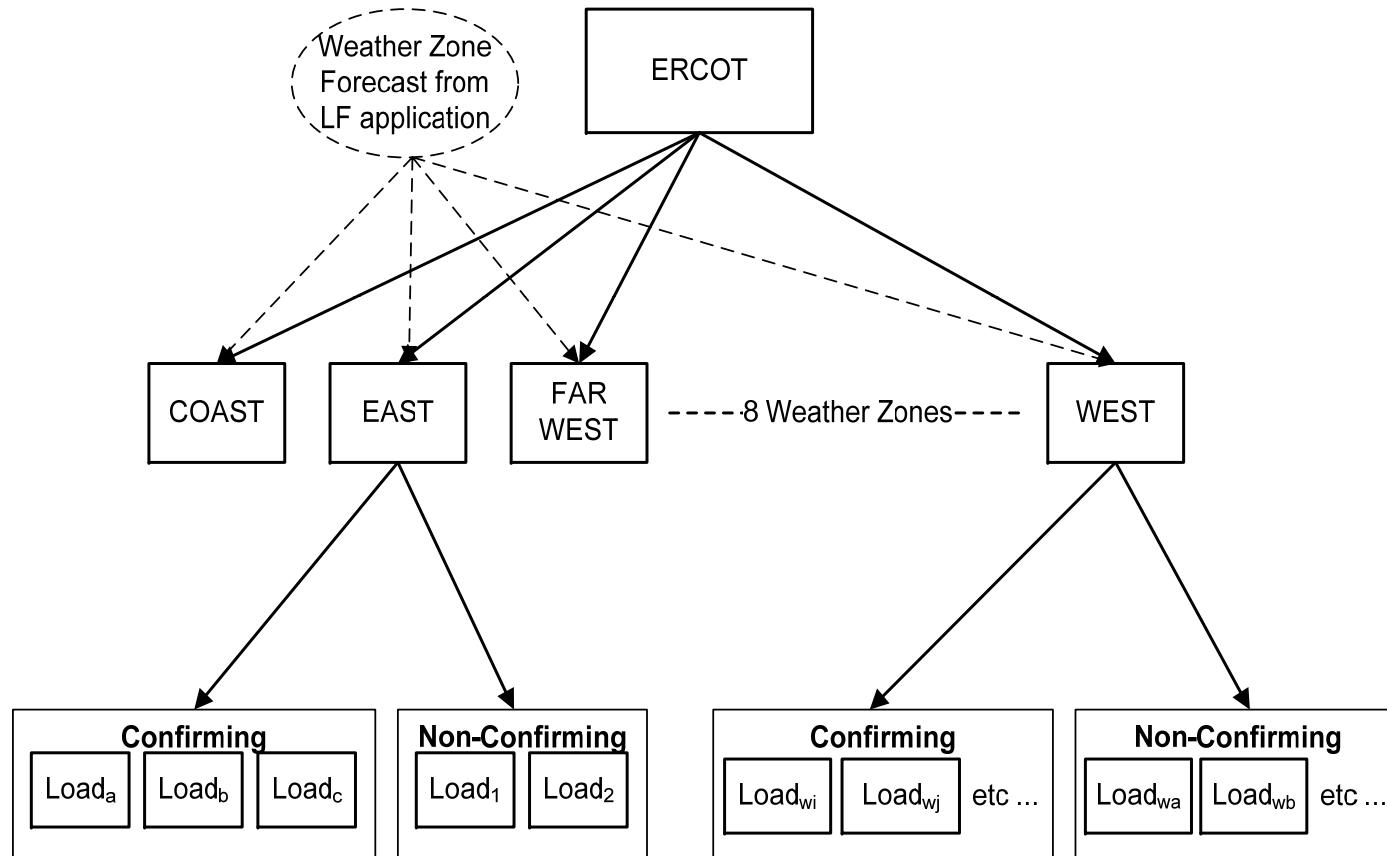

Fig 6: Load Schedules and Bus Load Forecast

Operator Overrides

- Breaker and Switch status
- Analog values

Measurement Relative Confidence Values -

- Zero Injection Bus** **0.001**
- True measurement** **0.01**
- Pseudo Measurement** **0.1**
- Stale measurement** **$0.01 * 3K$ (K=SE execution count since declared stale)**

- ❑ **Pseudo Measurements used to extend SE solution to unobservable parts of the network**
 - Derived from load predictions & generation schedules
 - Derived as calculations from telemetry
 - Operator entry
- ❑ **Old measurements used to maintain observability in the event of temporary loss of telemetry**
- ❑ **Appropriate confidence factor weightings used to avoid corrupting states estimated from telemetry data**

Questions ?

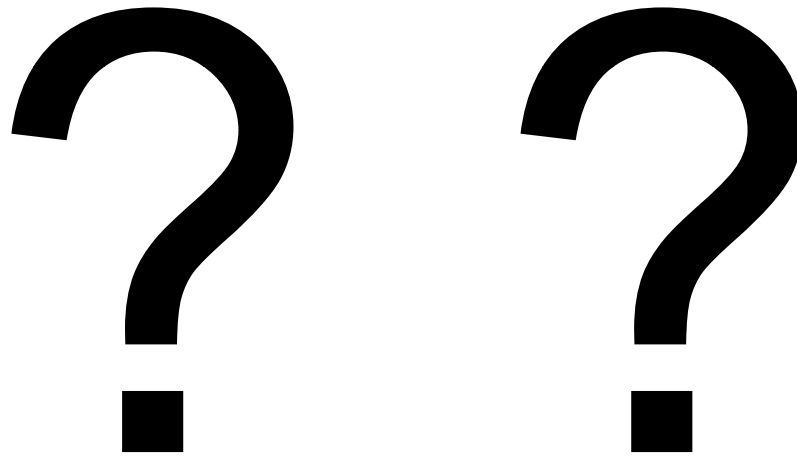

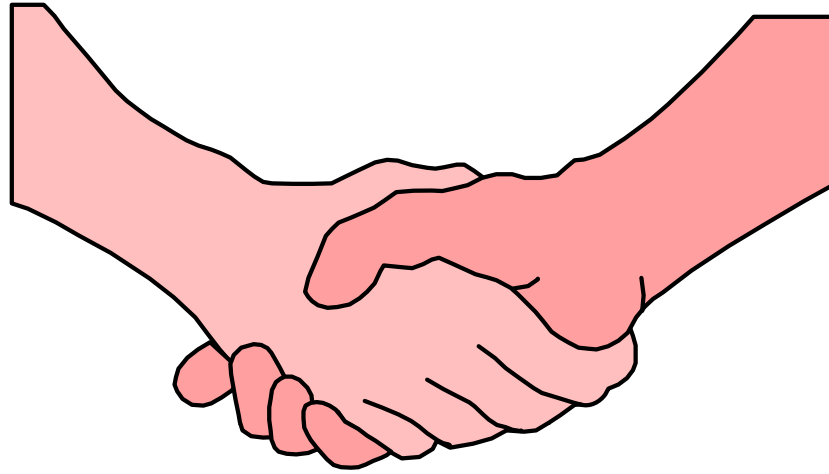

Thank U !!